



MECHATRONICS

INDUSTRIAL EQUIPMENT L.L.C.

DUBAI | RAS AL KHAIMAH | ABU DHABI | BAHRAIN | QATAR | INDIA

A Company established to Provide one stop solution for
Industrial and Process Automation.



www.mechatronics.ae





“We, the Mechatronics Group of Companies, firmly believe in delivering excellence through efficient, high-quality solutions and outstanding customer service. Our team understands your needs and offer customized solutions. We ensure 24/7 service support to be your reliable partners.

During the course of our journey, We have designed and developed many factory and process automation for prestigious multi-national companies like DEWA, Dubal, ADNOC, Emal, Nestle, Unilever, Jotun Paints, Coca-Cola, etc. We have successfully established as one of the go-to SPM manufacturers.

We firmly believe in performance and not in perishing.”

Stanley C. J. Daniel
Chairman and Managing Director



WHY CHOOSE US?



10 OFFICES



4 COUNTRIES



65 + TOP BRANDS



500+ EMPLOYEES



10000+ CUSTOMERS

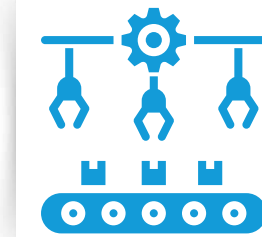

2 MANUFACTURING UNITS

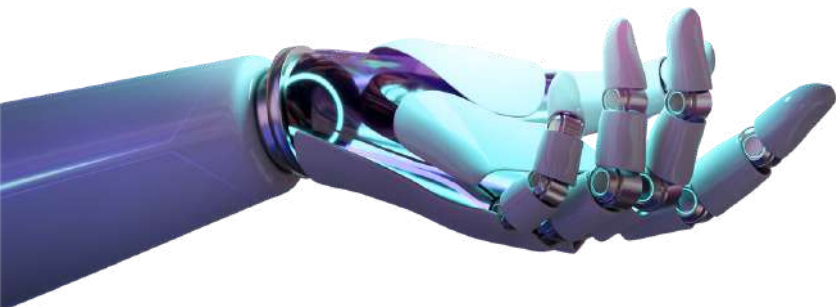



GLOBAL PRESENCE IN MIDDLE EAST AND IN INDIA

**Main Headquarters: Mechatronics Industrial Equipment FZ-L.L.C.
Dubai Production City, Dubai, U.A.E.**

Other branches in U.A.E.

- Abu Dhabi
- Ras Al Khaimah

Subsidiaries in the Middle East

- Bahrain
- Qatar

Further presence across the globe

- Chennai, Tamil Nadu, India - India Headquarters
- Sriperumpudhur, Tamil Nadu, India - Factory
- Delhi, Mumbai, Pune, Bengaluru, Ahmedabad, Kolkata, Hyderabad, Jamshedpur, Coimbatore - Regional presence





HOW WE WORK?

01



Customer Requirement
Your Needs, Our Passion

02



Project Design
Crafting Your Perfect Blueprint

03



Customer Approval
Your Green Light, Our Go Signal

04



Product Supply
Sourcing Quality Solutions

05

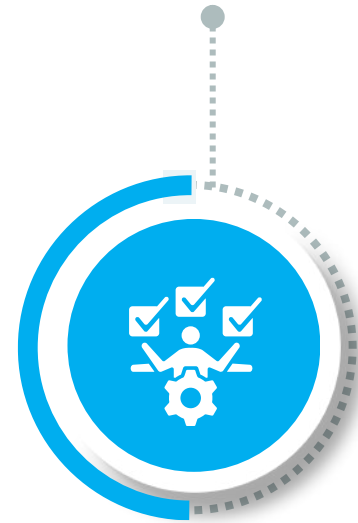

Project Execution
Bringing Your Vision to Life

06



Quality Checkpoint
Ensuring Excellence at Every Step

07



Installation
Installation and Training will
be done

08



After-Sales Support
Unmatched 24/7 After-Sales Care

09

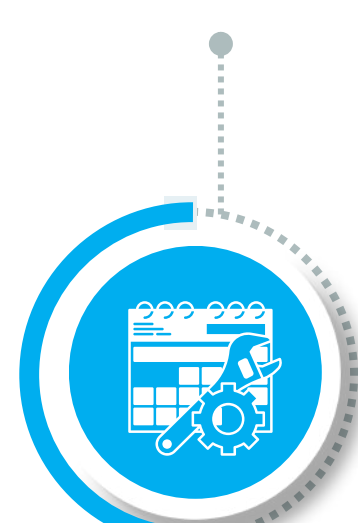

AMC Solutions
Partnering for Perpetuity



MAIN APPLICATION FIELDS



CEMENT

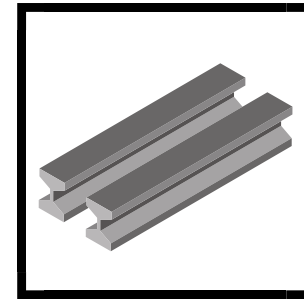

STEEL INDUSTRY

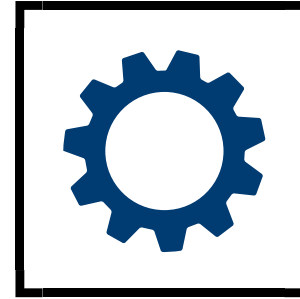

OEM



OIL & GAS



PHARMACEUTICAL



FURNITURE

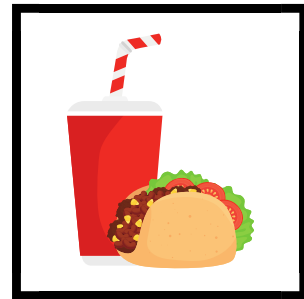

FOOD & BEVERAGE



HVAC



MARINE

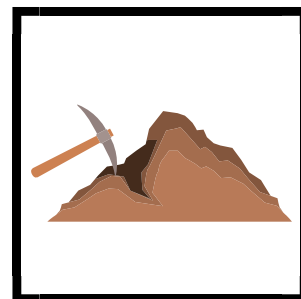

MINING

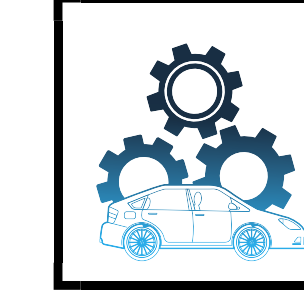

AUTOMOTIVE



MEDICAL

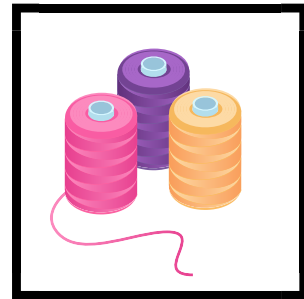

TEXTILE

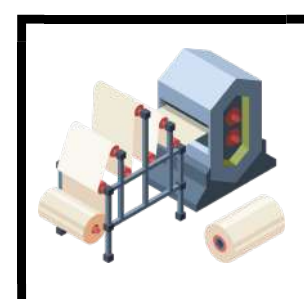

PAPPER INDUSTRY

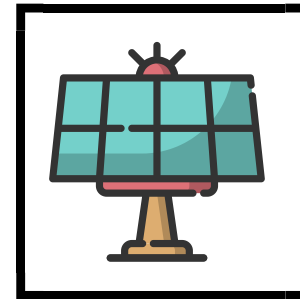

SOLAR INDUSTRY

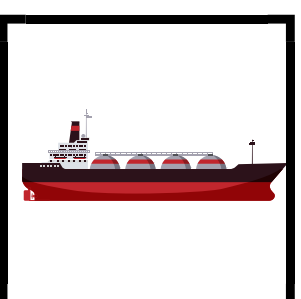

LNG PLANTS

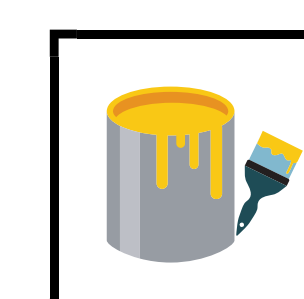

PAINTS



WATER TREATMENT



OUR PRINCIPALS

FESTO



VALBIA VALPRES



4G GHIDINI S.r.l. STUBBE



STABILUS



NetterVibration



pneumatech



Elektror
airsystems gmbh





WE PROVIDE SOLUTIONS ON

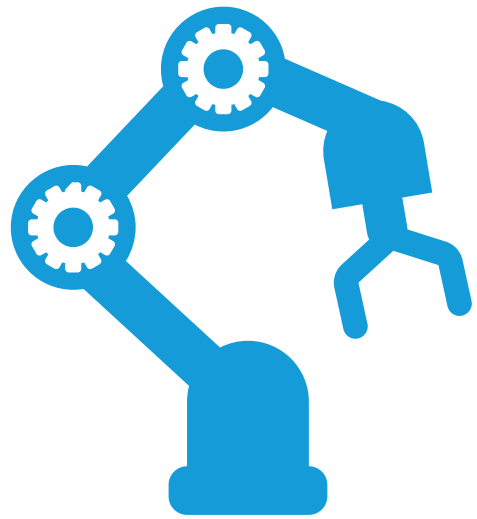

FACTORY AUTOMATION

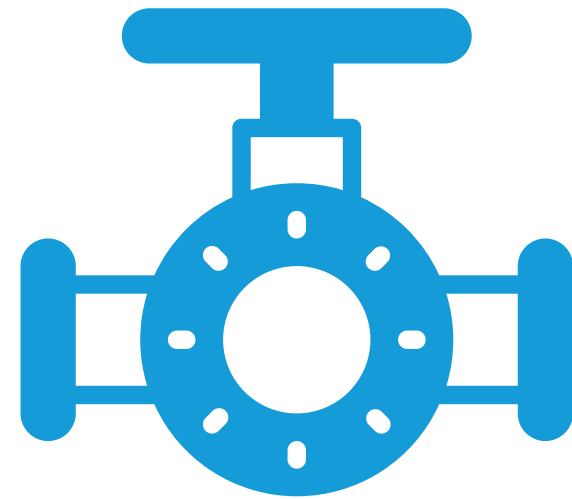

PROCESS AUTOMATION

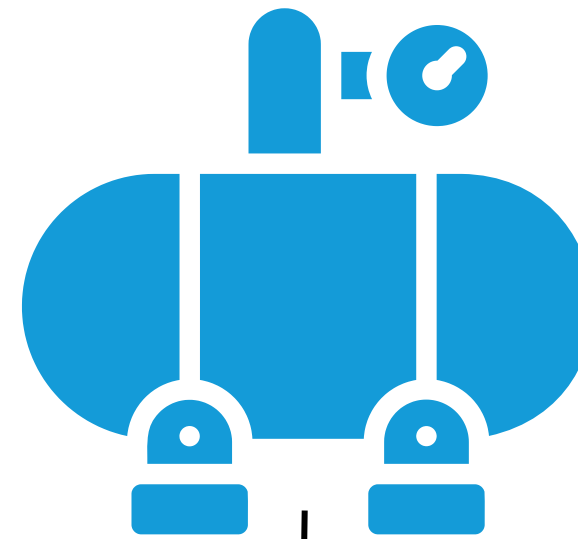

EQUIPMENT DIVISION



HYDRAULIC DIVISION

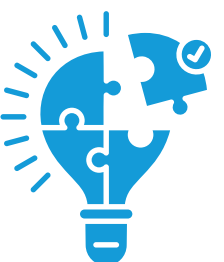

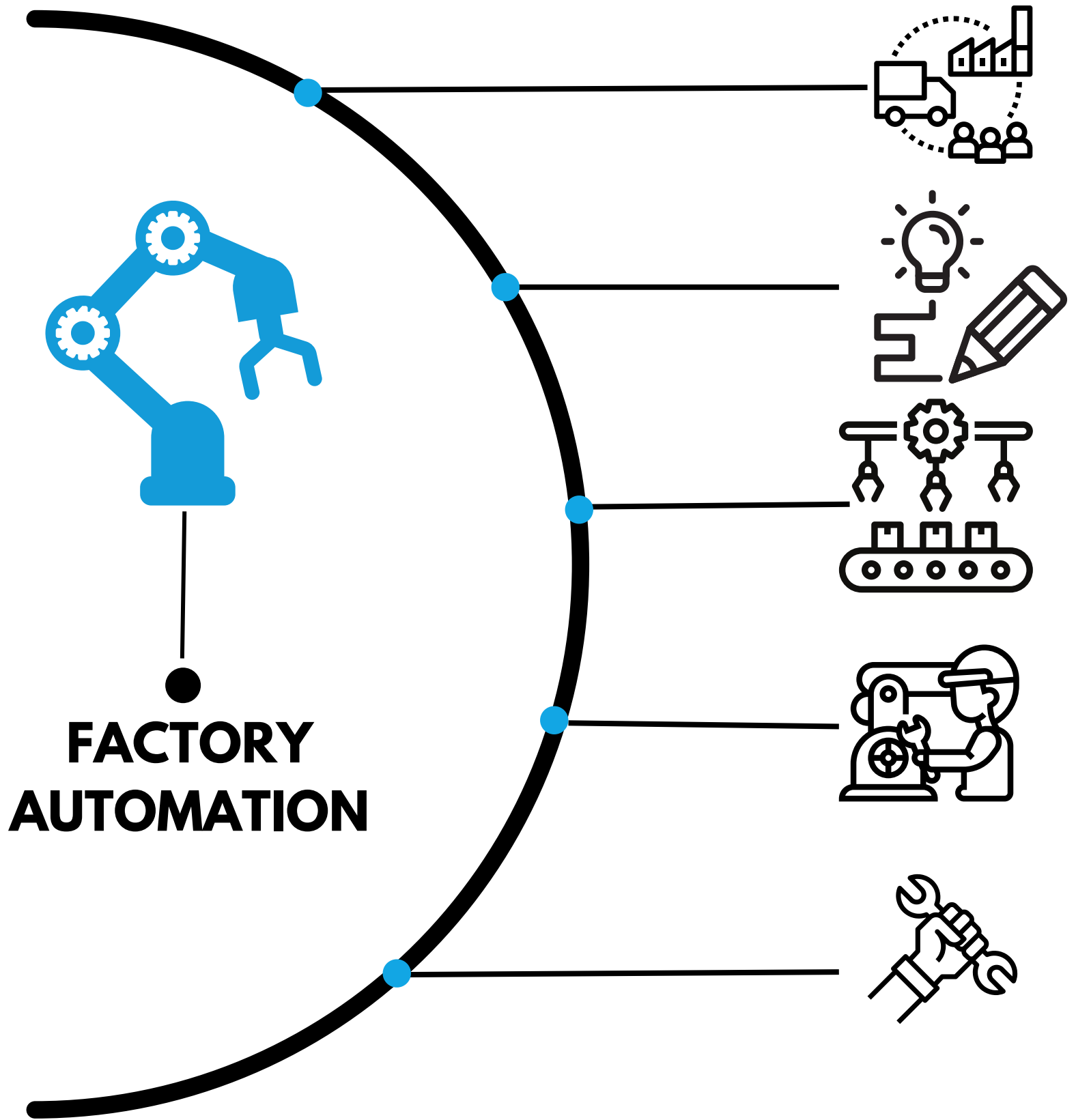

**FACTORY
AUTOMATION**

SUPPLY

DESIGN & AUTOMATION

SPM MANUFACTURE

INSTALLATION

SERVICE

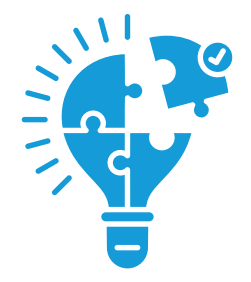

WE IMPROVE YOUR LIFE





FESTO GERMANY

FESTO AG has pioneered many new product ideas and introduces more than a hundred new pneumatics products each year. These make up an intelligent, holistic system consisting of controllers, valves, valve terminals, cylinders, air preparation components, pneumatic modules and electrical / electronic controllers to complete automation systems.

You can choose from over 45000 FESTO products and turnkey pneumatic control systems, cylinder / valve combinations, application optimized pneumatics & programmable logic controllers (PLC) to suit individual needs.



SERVO DRIVE CMMT



STANDARD BASED CYLINDER



PRESSURE REGULATOR LR



FLANGED PRESSURE GAUGE



SERVICE UNIT FRC



VALVE TERMINAL MPA

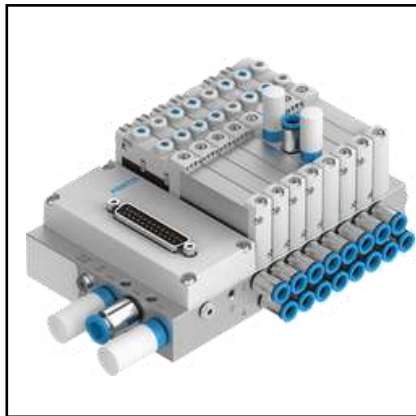

VALVE TERMINAL VTUG



VALVE TERMINAL VTUS



GUIDED DRIVE DFM



ELECTRIC CYLINDER ESBF



SERVICE UNIT COMBINATION MSB6



PRESSURE SENSOR

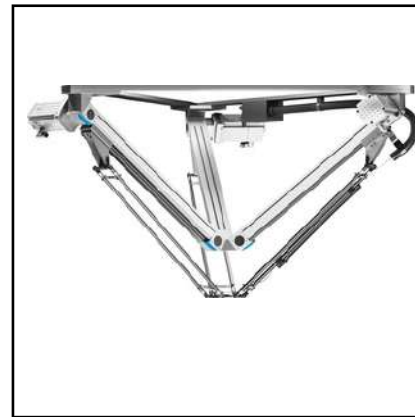

HANDLING SYSTEM



SEMI-ROTARY



PARALLEL GRIPPER



SILENCERS

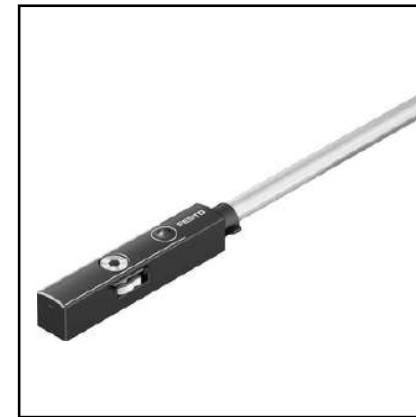

PROXIMITY SENSOR



HAND LEVER VALVE

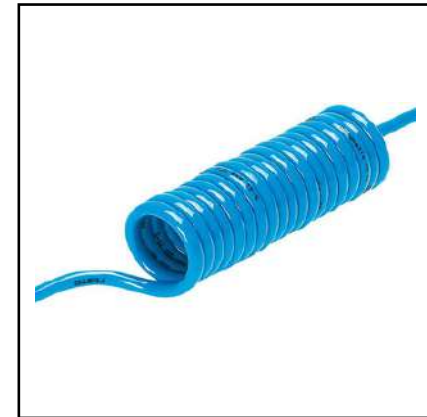

SPIRAL HOSE



TUBINGS



FITTINGS



AIR GUN AND NOZZLE



COMPACT CYLINDER



CYLINDER WITH CLAMPING

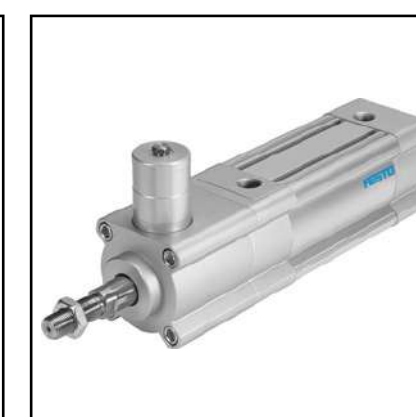

CYLINDER WITH ACCESSORIES



SERVICE UNIT COMBINATION



DSBC CYLINDER



MEDILINE[®] and CARELINE System
 Hospital and Care Sectors



HOMELINE System
 Domestic Furniture, Actuator systems for Leisure Beds, Recliners, Sofas and Massage Chairs



DESKLINE System



TECHLINE System
 Industrial Actuator systems for mobile as well as stationary applications



APPLICATIONS

Business areas for electric linear actuators

Our actuators can be found anywhere, in homes, offices, hospitals, factories, farms, and much more. They bring movement to the office and to homes - adjustable desks, kitchen elements, beds, and couches.





Lift-O-mat gas spring



Lift-O-mat PTL gas spring



Inoxline gas spring



Bloc-O-lift gas spring



Stab-O-shoc gas spring



Stab-O-mat gas spring



Gas spring assembly programme

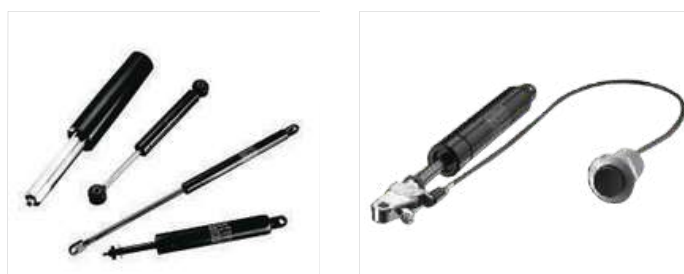

Stabilus gas springs, gas struts & dampers



Bloc-O-lift gas spring with soft touch button



Lift-O-mat gas spring with locking tube

VIBRATORS
Pneumatic / Electrical / Hydraulic



CHEMICAL PUMPS



Air operated double diaphragm pumps



Quantum pumps polymer version for water treatment and chemical processes



Stainless steel air operated double diaphragm pump (food grade)



Double hardness DURAFLEX cups – mark free



Friction cups for oily sheet metal



Pi GRIP bag lips detectable cups – FDA approved



metal & wood – markfree



Pi COMPACT vacuum generators with integrated functions



VGS Vacuum generator with suction cup - decentralized application



Pi CLASSIC vacuum pump



P6010 Heavy duty vacuum pump



Vacuum conveying system



Pi FLOW conveyor for various industries



Conveyor vacuum pump



Filters

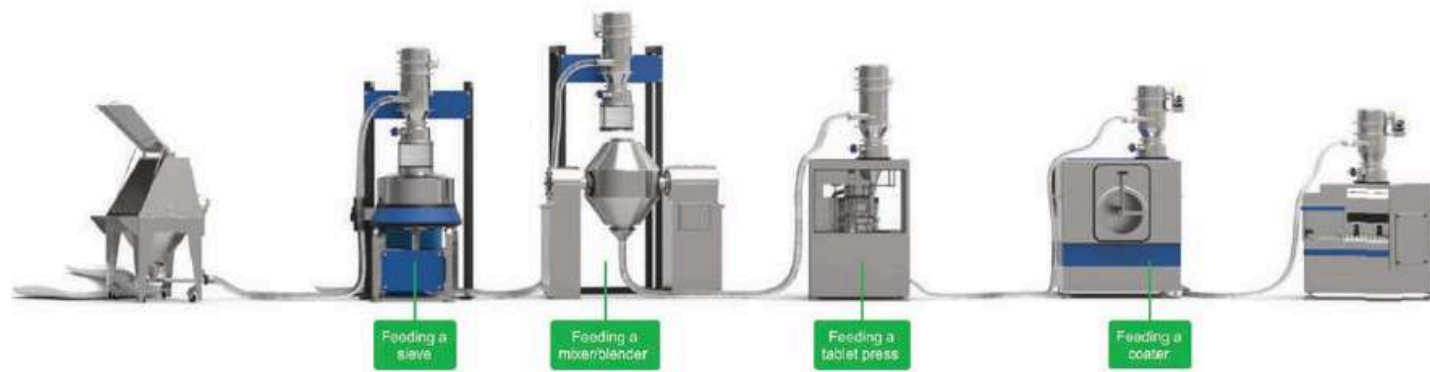

Reduce Product scrap & contamination

Small Footprint

Minimum Maintenance

Dust Free Working Environment

Vaculex



Vaculex is a world leading manufacturer of lifting systems based on vacuum technology. Our goal is to make your work

Kenos Vacuum Gripping Systems



Kenos® vacuum grippers are designed and optimized to be used in various applications e.g. packaging, wood, dimensions and compactness.

Applications and Solutions

Vacuum in the Packaging Process

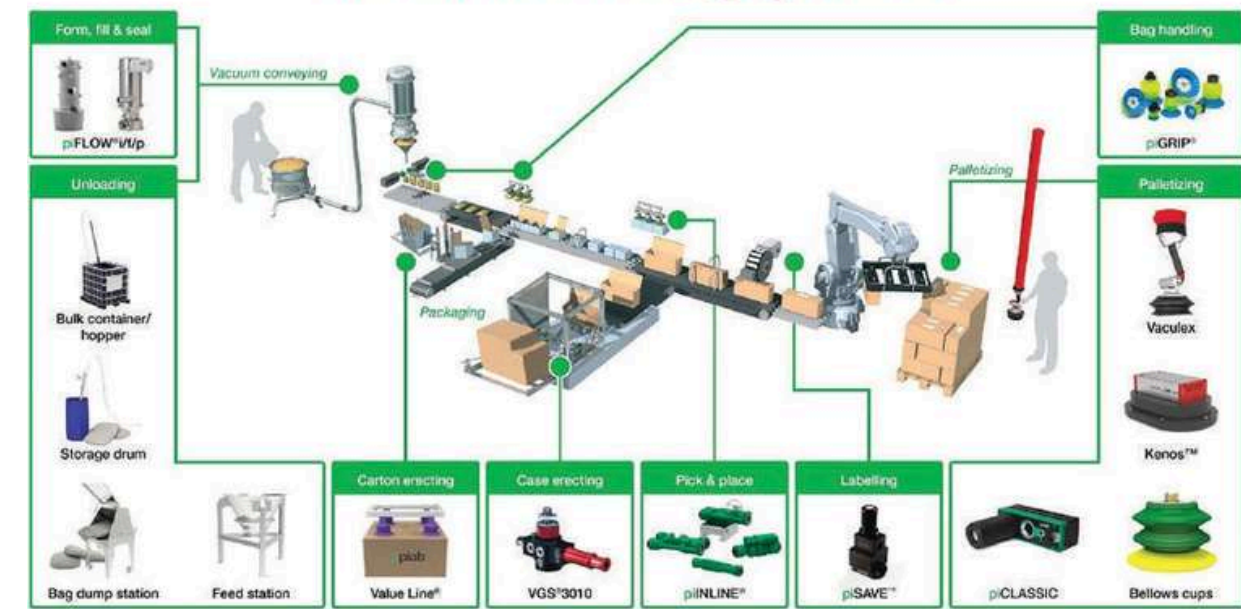

Reduce Product scrap & contamination Small Footprint Minimum Maintenance Dust Free Working Environment



SPM PROJECTS & CONTROL CABINETS



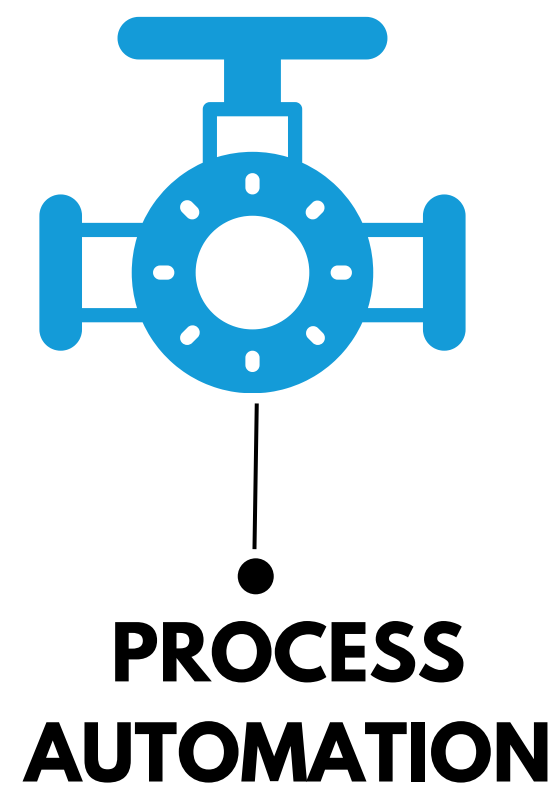
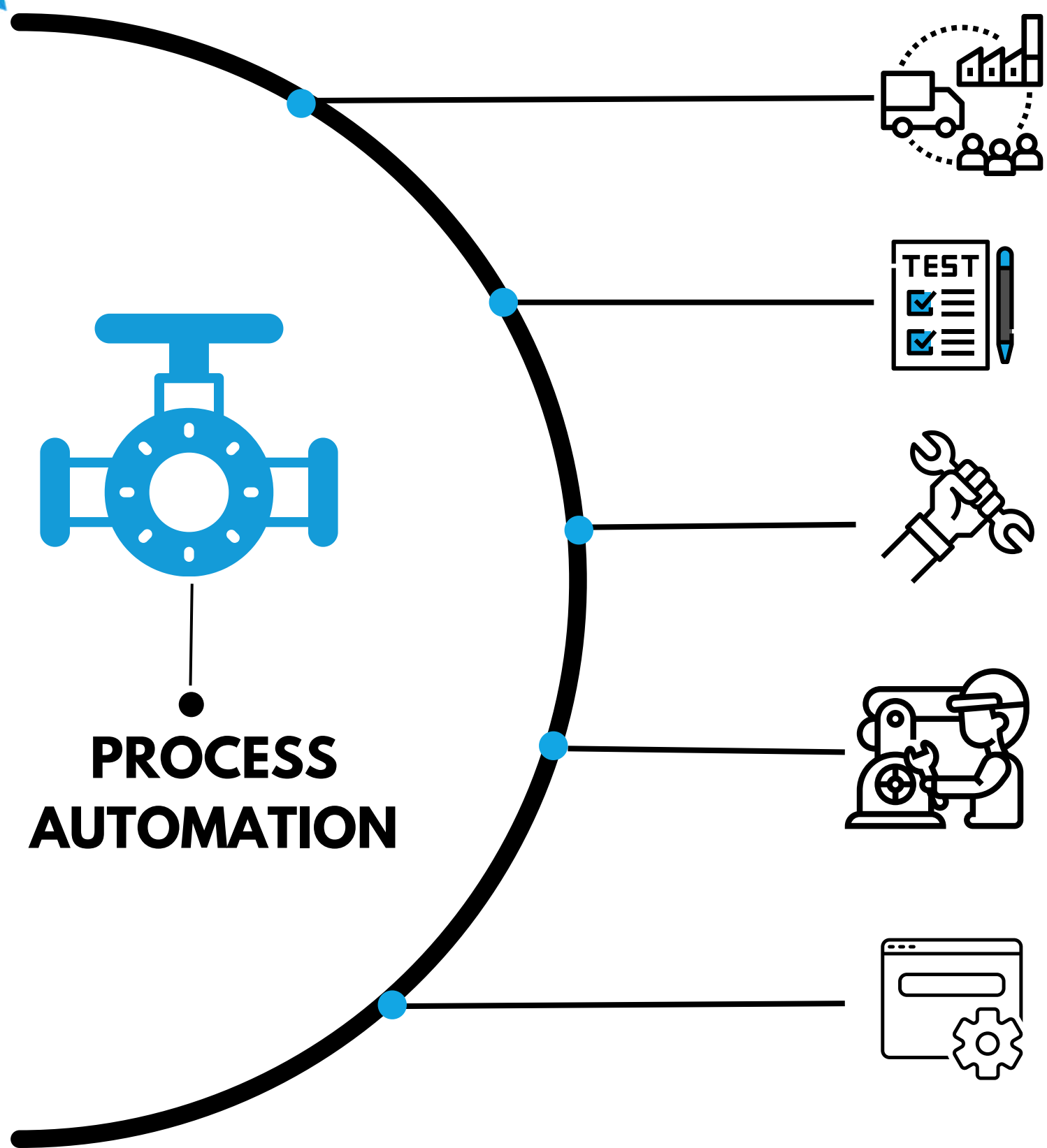

SUPPLY

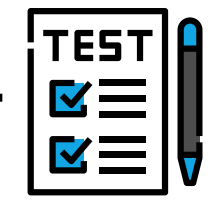

VALVE TESTING

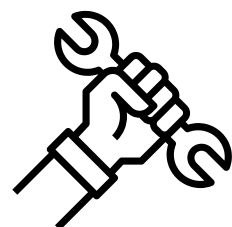

SERVICING

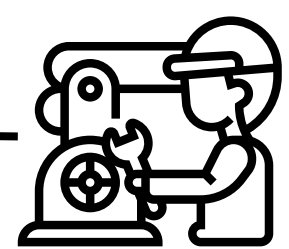

INSTALLATION

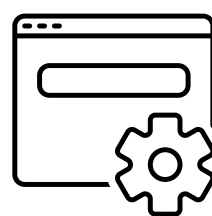

MAINTENANCE



FESTO

EFFEBI

VALPRES

QUAM

VALBIA

penta s.r.l.
metal seated ball valves

IMT
SWITZERLAND

GIBSON
valves

FIP

STÜBBE

4G GHIDINI S.r.l.

belven
Involved as promised

italvalvole 48th
di SPADON OSCAR & C.

MIX Srl unipersonale
MIXING SYSTEMS AND
COMPONENTS FOR PLANTS

ORBINOX
VALVE SOLUTIONS IN MORE THAN 70 COUNTRIES



RANGE OF VALVE WE SUPPLY AND SERVICE

- Gate Valves
- Globe Valves
- Ball Valves
- Butterfly Valves
- Plug valves
- Segmented control Valves
- V angle Valves
- Pinch Valves
- Dampers
- Valve Actuators



OIL AND GAS / FUEL AND PETROLEUM

- Oil processing
- Transportation
- Distribution
- Storage



POWER AND ENERGY

- RMS
- Energy
- Co-generation Power plant
- Hydropower Plant



WATER PLANT & PIPELINES

- Waste water & geothermal water
- sea water and Water treatment
- Hot Water
- Water Storage and transportation

Belven is a Belgium based company with over 40 years of experience in valves production. We are present in over 50 countries and have solutions for both the building and the industrial market.



BUTTERFLY VALVES-BARE SHAFT

Wafer type butterfly valve, mounting between flanges PN10/PN16/A150, bare shaft



BUTTERFLY VALVES-DOUBLE ACTING

Wafer type butterfly valve, mounting between flanges PN10/PN16/A150, with double acting actuator



BUTTERFLY VALVES-GEARBOX

Wafer type butterfly valve, mounting between flanges PN10/PN16/A150, with gearbox



BUTTERFLY VALVES-LEVER

Wafer type butterfly valve, mounting between flanges PN10/PN16/A150, with lever



KNIFE GATE VALVES-HANDWHEEL + POSITION INDICATION

Knife gate valve, uni-directional, to be mounted between flanges PN10, with rising stem, position indicator and non-rising handwheel



GATE VALVES-HANDWHEEL

Gate valve, flanged PN16, resilient seated, F4 short face to face, with handwheel



GATE VALVES-HANDWHEEL

Gate valve, flanged PN16, resilient seated, F4 short face to face, with handwheel



GATE VALVES-BARE SHAFT

Gate valve, flanged PN10, resilient seated, F5 short face to face, bare shaft with ISO 5211 flange for automation



BALL VALVES - DOUBLE ACTING

Ball valve, full bore, split body, flanged PN16, with double acting actuator



BALL VALVES-BARE SHAFT

Ball valve, full bore, split body, flanged PN10/PN16/PN40, bare shaft



BALL VALVES-LEVER

Ball valve, full bore, split body, flanged PN10/PN16/PN40, with lever



KNIFE GATE VALVES-LEVER

Knife gate valve, uni-directional, to be mounted between flanges PN10, with quick opening lever



EFFEBI, ® with fifty years' experience in the production of brass valves, has operated in all fields of civil and industrial engineering, offering a vast range of increasingly innovative and tested shut-off valves.



BALL VALVES-MOON SERIES-3WAY

- PTFE+15% GLASS FIBRE: + 190° C.
- PTFE+CARBOGRAPHITE: + 200° C
- Ball with relief hole
- PN40 DN65 - DN100.



BALL VALVES-MOON SERIES- OT58

- PRESSURES: PN16.
- TEMPERATURE: -20° C / +150° C for fluids
20° C / + 60° C for gas.
- CONNECTIONS with flanges: UNI-EN 1092 and
DIN 2501 BL.1.



BALL VALVES FLAT BODY FLANGE TYPE

- PTFE+ 15% GLASS FIBRE + 190° C.
- PTFE + CARBOGRAPHITE +200° C
- Special thread: UNC
- Heating jacket (see MOON CR)



BALL VALVES-TITAN

- PRESSURES: PN140 1/4" - 1"
PN100 1"1/4 - 2".
- TEMPERATURE LIMITS:-20° C / +150° C (PTFE)
- CONNECTION: F/F Rp UNI ISO 7/1 (UNI EN
10226.



VALVES WITH PNEUMATIC ACTUATOR

- STANDARDS: BS EN 593 - (BS 5155) - MSS
SP67 - API 609.
- TEMPERATURE: -20° C / +90° C.
- MAXIMUM SUPPLY PRESSURE: 10 bar.



VALVES WITH ELECTRIC ACTUATOR

- ROTATION ANGLE:90° .
- TEMPERATURE LIMITS: -20° C / +70° C.
- SUPPLY VOLTAGE:24 - 240V.*
- PROTECTION DEGREE: IP67



BALL VALVES-ANTARES

- PTFE+CARBOGRAPHITE: use up to +200° C
- Peek for high temperatures up to +260° C
- Body, body flange, stem ,ball made of AISI
316L



BALL VALVES FOR GAS

- The ATHENA series is particularly
recommended in gas installations.
- TEMPERATURE LIMITS: from -20° C to +60° C
- PRESSURE LIMITS: MOP5



Valbia was founded in 1995 and it is the only company in Italy specialized in the production and in the international distribution of electric and pneumatic actuators.

After more than 25 years, success is constant, thanks to a complete range in continuous expansion which includes not only actuators but multiple combinations of automated valves, suitable for the most different kinds of applications.



ELECTRIC ACTUATORS

MOD: VB030

Torque: 30

Voltage: 12 AC/DC - 240V AC



ELECTRIC ACTUATORS

MOD. VB350M

Torque: 350

Voltage: 12 AC/DC - 240V AC

Speciality for : Oil And GAs



2 WAY WAFER BALL VALVE



2 WAY ELECTRIC PACKAGES



3 WAY ELECTRIC PACKAGES



3 WAY POLISHED BALL VALVE



VALPRES

ITALY

Valpres, born in 1978, has built its corporate identity on values such as experience, reliability and innovation. The main goal has always been to put the customer at the center of the entire supply chain, from production to delivery, always aiming for their complete satisfaction.

Over the years, the energy division, which produces customized valves for the Oil&Gas and renewable energy sectors, joins the industrial one. A continuous challenge to be reliable protagonists and partners also in the ecological transition.

BUTTERFLY VALVE
BUTTERFLY VALVE WAFER TYPE PN16



WAFER BALL VALVES
FULL BORE FLANGED BALL VALVE PN16



3 WAY BALL VALVE
STAINLESS STEEL , FOUR SEALS, FEMALE
THREADS.



3 WAY BALL VALVE
FLANGED PN16 DIVERter BALL VALVE,2SEATS



3 WAY BALL VALVE
FLANGED PN16 DIVERter BALL VALVE,4SEATS





QUAM s.r.l. has been a market leader operating since 2001 in the design, manufacturing and supply of complete Wellhead Equipment for the Upstream Onshore and Offshore Oil and Gas Industry, including API 6A Valves and WELL Protection Systems.

QUAM is a customer oriented company and a short lead-time manufacturer specializing in fast track projects and Severe Service applications.

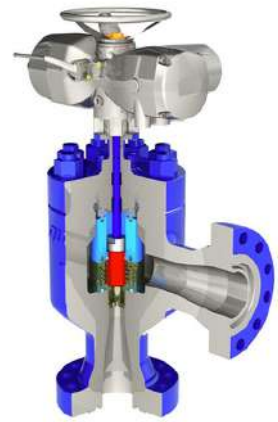

CHOKE VALVES -D/M SERIES

The QUAM Multistage Choke Valves -D/M Series is used where high pressure drops and high fluid velocity might cause cavitation issues, high noise levels, excessive vibrations, etc.



GATE VALVE GAV-ELE SERIES

The QUAM GAV-ELE Series is a Full bore through conduit Slab Gate Valve complete with Rising Stem Electric Actuator
GAV-ELE is the typical Electric Gate Valve suitable for installation on Christmas Trees, Choke & Kill or Production Manifolds

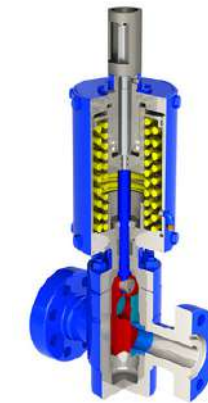

GATE VALVE GAH-SDV SERIES

The QUAM GAH-SDV Series is an Full bore through conduit Slab Gate Valve. GAH-SDV is the typical API-6A Hydraulic Gate Valve suitable for installation on Christmas Trees, Choke & Kill or Production Manifolds



QUAM MECHANICAL HIPPS SYSTEM

QUAM mechanical High Integrity Pressure Protection System is a self-contained equipment suitable for applications where no external power sources are available.



QUAM ELECTRONIC HIPPS

Considerably reduces overpressure process risks and environmental impacts with lower weight and cost for piping and vessels downstream the system itself.



BALL VALVES MADE IN ITALY OVER 45 YEARS OF BALL VALVES ENGINEERED FOR CUSTOMER PURPOSES

Since 1977 Penta has been a leading company in the metal seated ball valves sector for extreme temperatures, in fact, its products are synonymous of Quality and Reliability as the result of constant investment in Research and Development of technological solutions without equal in the sector.



2-PIECE THREADED BALL VALVE FOR MEDIUM TEMPERATURES

DIMENSION RANGE: DN 1/2" - DN 2"
CONSTRUCTION: Floating Ball, Full Bore, 2-piece threaded
TEMPERATURE RANGE: -50°C / +400°C



WAFER BALL VALVE FOR MEDIUM TEMPERATURES

DIMENSION RANGE: DN 1/2" - DN 6"
CONSTRUCTION: Floating Sphere, Full Passage, Wafer
TEMPERATURE RANGE: - 50°C / +400°C



BALL VALVE FOR ABRASIVE SERVICES

CONSTRUCTION: Floating or Trunnion Ball, Full or Reduced Passage, Split Body
SIZE RANGE DN 1/2" - DN 6"
TEMPERATURE RANGE: - 100°C / +400°C



METAL SEATED BALL VALVES FOR CRYOGENIC

DIMENSION RANGE: DN 1/2" - DN 10"
CONSTRUCTION: Floating or Trunnion Ball, Full or Reduce Bore, Split Body.
TEMPERATURE RANGE -200°C / +700°C



METAL SEATED BALL VALVE FOR HIGH TEMPERATURE

DIMENSION RANGE: DN 1/2" - DN 18"
CONSTRUCTION: Floating or Trunnion Ball, Full or reduce Bore, Split Body
TEMPERATURE RANGE: 100°C / +720°C

FESTO AG has pioneered many new product ideas and introduces more than a hundred new pneumatics products each year. These make up an intelligent, holistic system consisting of controllers, valves, valve terminals, cylinders, air preparation components, pneumatic modules and electrical / electronic controllers to complete automation systems.

You can choose from over 45000 FESTO products and turnkey pneumatic control systems, cylinder / valve combinations, application optimized pneumatics & programmable logic controllers (PLC) to suit individual needs.



SINGLE AND DOUBLE ACTING ACTUATOR

features a gear rack and pinion combination with a constant torque characteristic across the entire swivel range. Sizes 10 to 2300. Suitable: butterfly valves, ball valves and air dampers.



POSITIONER

- Digital, electropneumatic positioner
- Simple and efficient position control of single- and double-acting pneumatic rotary and linear drives



SENSORBOX

Limit switch boxes SRBC are used for electrical feedback and control of the position of process valves actuated using pneumatic quarter turn actuators.



SOLENOID VALVE

- Namur connection pattern to VDI/VDE 3845
- Rotatable seal for 3/2- or 5/2-way valve
- Sturdy and powerful
- Extended temperature range



EXPLOSION PROOF SOLENOID VALVE

- A complete and comprehensive range with 5/2-way and 5/3-way valves
- Pneumatic connections G1/8, G1/4, G3/8

CUSTOMIZED CONTROL CABINET



ELECTRONIC PROXIMITY SWITCH

For T-slot, can be inserted from above; commissioning without a power supply is quick, easy and very reliable, without the need for precision adjustment or re-adjustment, either via auto teach-in or programming



FILTER REGULATOR LUBRICANT

- Depending on the application, combination of filter regulator, filter, lubricator, on/off valve, soft-start valve, branching module
- Grid dimension 40mm



Tired of Manually Operating Valves?

MECHATRONICS OFFERS IMPACTFUL VALVE AUTOMATION SOLUTIONS

Valve automation uses actuators to operate valves automatically, ensuring precise control and efficiency across various applications. This technology enhances remote operation, safety, and system performance.

Our Services Include:

- Customized Valve + Actuator Integration
- Testing
- Repair and Maintenance

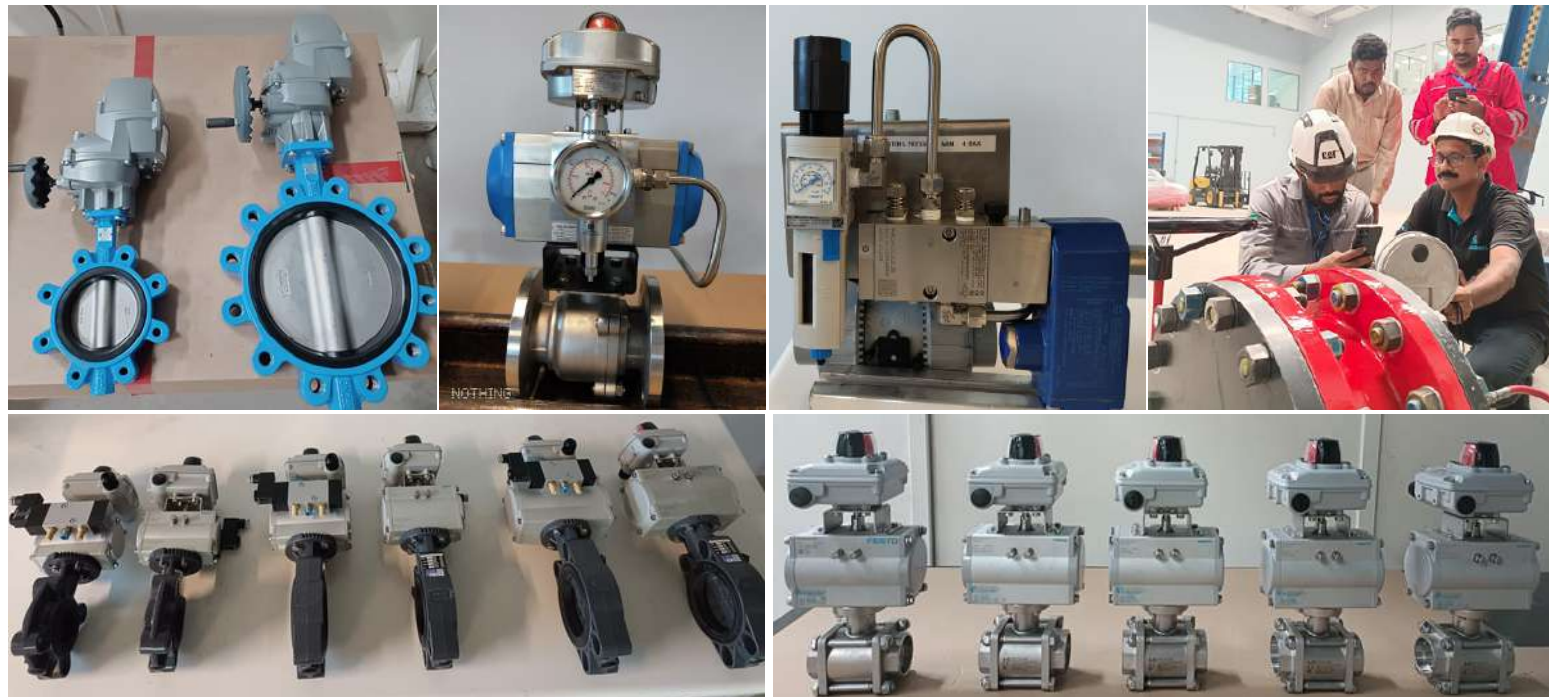

EXPERTISE

Our engineers are factory-trained and equipped with the latest product knowledge, ready to tackle industry challenges. We specialize in new product installations, valve integration, and preventive maintenance of existing equipment.

OUR OFFERINGS

As representatives of reputed products and principals in the UAE, Mechatronics provides a comprehensive range of solutions, including manual valves, actuators, customized integrations, and various flow control solutions.



WHY CHOOSE US?

-  24/7 Service Support
-  Onsite / Offsite Service
-  One-stop Solution provider
-  Multi-brand custom integrations



Efficiency
Consistent, precise control reduces errors



Safety:
Reduces human intervention risk



Cost Savings:
Lowers labor and maintenance costs



Reliability:
Ensures critical process dependability



Scalability:
Easily adaptable to varying operational demands



VALVE TESTING

During our testing procedures, we conduct Pressure tests using Hydro, Pneumatic, and Nitrogen methods across a wide range of valve sizes, from 1/4" to 48".

Our comprehensive testing covers various valve types, including

- Ball Valves
- Butterfly Valves
- Gate Valves
- Globe Valves
- Plug valves
- Check Valves
- Steam trap
- Strainer





SUPPLY AND SERVICING OF PROCESS VALVES



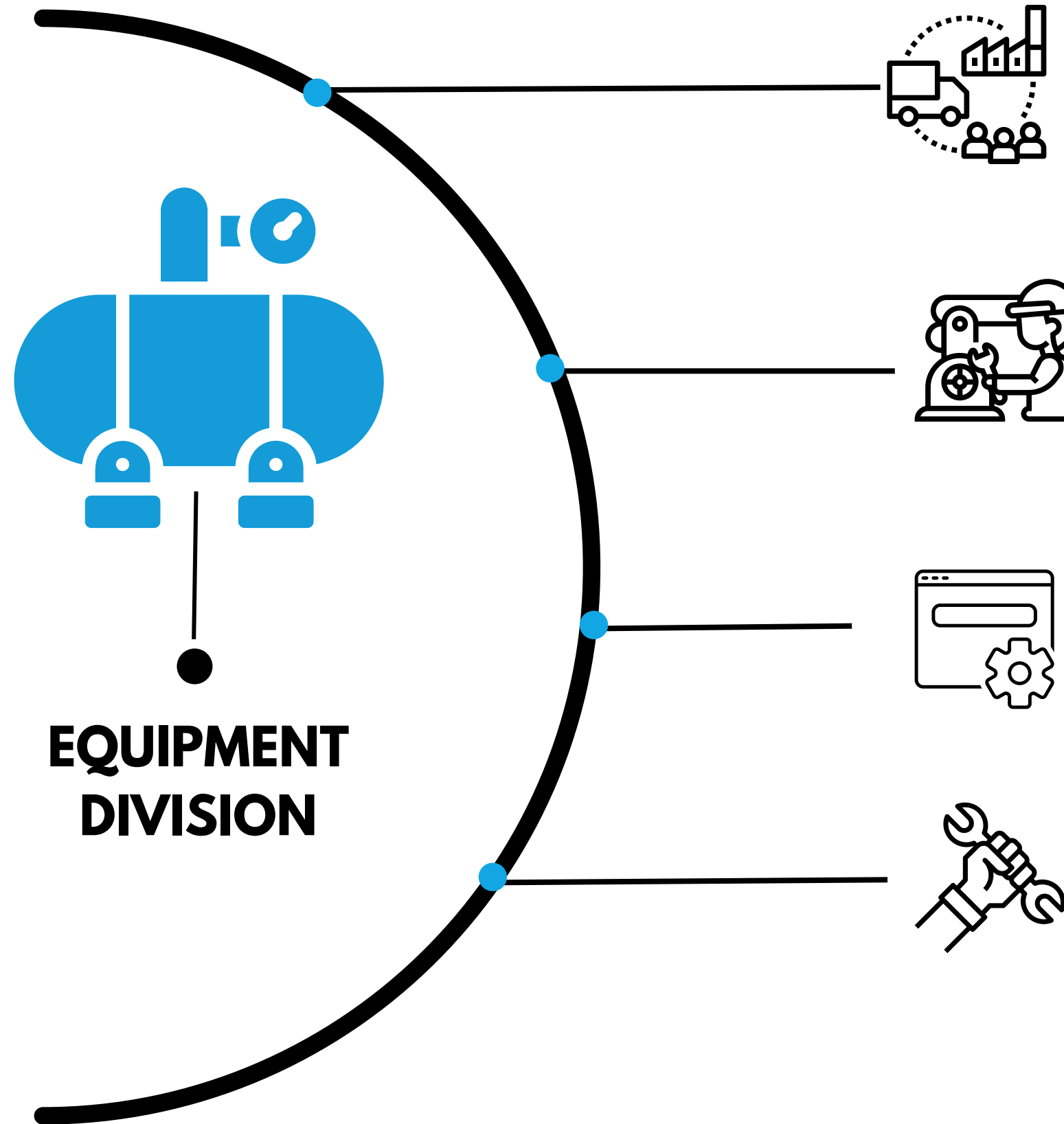

SUPPLY



INSTALLATION

MAINTENANCE

SERVICING

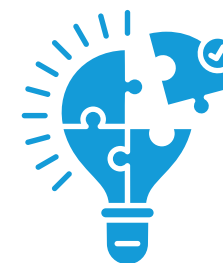



ROTARY SCREW COMPRESSOR



SILENT

⚙️ GEARBOX DRIVEN SCREW COMPRESSOR ⚙️ CONTINUOUS 🗣️ SILENT 69-74 Db (A) ⚙️ 3840-15720 I/MIN
⚙️ 40-125HP / 30-90K 📏 7-13 bar / 100-190psi 📊 760-1570 kg

INVERTOR DRIVEN COMPRESSORS CPVS SERIES 30 – 110 KW / 40 – 150 HP



ROBUST AND POWERFUL COMPRESSOR WITH INTEGRATED SOLUTIONS

- 1 FILTERATION PANEL
- 2 EMERGENCY STOP
- 3 CONTROLLER
- 4 AIR COOLER
- 5 OIL COOLER
- 6 OIL-SEPARATOR VESSEL
- 7 INVERTER
- 8 INTEGRATED DRYER

AIR FILTER



OIL - WATER SEPERATOR



- 🌀 OIL FILTER
- ⚙️ CONTINUOUS
- 🔥 FILTRATION
- 📏 43-2430 m3/h
- ⚙️ 16 Bar
- 📊 1, 0-12, 16kg

COMPRESSED AIR PURITY STANDARD TO ISO 8573 : 1:2010

RECIPROCATING COMPRESSOR



Direct Driven

📏 1,5 - 3 hp ⚙️ 8- 10 bar



One Stage

📏 2 - 4 hp ⚙️ 10 bar



Two Stage

📏 2 - 2.5 hp ⚙️ Models upto 15 Bar

REFRIGERANT DRYERS



INNOVATIVE DESIGN CONCEPT

- 1 Refrigerant Compressor
- 2 Condenser
- 3 Heat Exchanger With High Thermal Exchange and Low Pressure Drop
- 4 Automatic Condensate Discharge
- 5 Electronic Dew Point Indicator

🔥 Refrigerant Dryer ⚙️ Continuous 🔥 Dry 🗣️ Silent: 47 - 74 dB(A) 📏 21 - 5040 m3/h 📏 0 - 13, 12 - 3kW ⚙️ 13 or 16 bar 📊 19 - 650 kg

COMPLETE TURNKEY SOLUTION

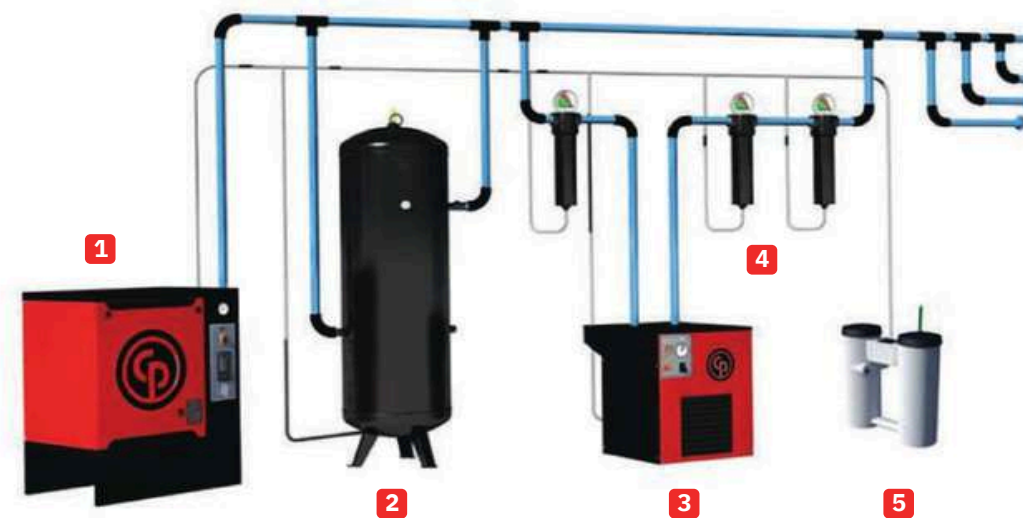

1 Compressor 2 Air Tank 3 Refrigerant Dryer 4 Filter 5 Oil-water Separator





CP Compact angle die grinder



CP Die grinder



CP Great performance impact wrenches



CP Industrial angle grinder



CP Industrial angle grinder



CP Lightweight angle grinders



CP One hand control die grinder



CP Series die grinder



CP Compact angle die grinders



CP Mini air drill



CP Composite Impact Wrench

Product Specification

MechAir Superior Aluminium Air Pipes



(5.8m / 19.02 ft.)

Resistance to:

- ▶ Ultraviolet rays
- ▶ Mineral and synthetic compressor lubricants
- ▶ Environmental weather conditions
- ▶ Mechanical Shocks



Aluminium Fittings



Power Saving



Fire Retard



Quick Installation



No Leakage



With Auto Drain



Corrosion Free

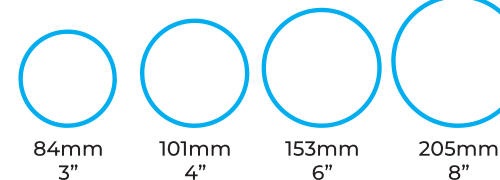
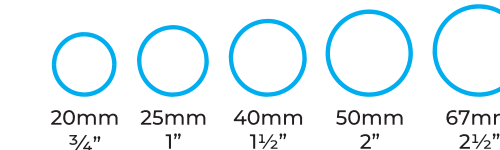

Compatible Fluids:

- ▶ Compressed air
- ▶ Vacuum
- ▶ Inert Gas

Fire Resistance:

- ▶ The system does not stroke or propagate any fires
- ▶ High quality powder coated exterior

General Technical Specifications:

- ▶ Max. working pressure: 16 bar
- ▶ Working Temperature: -20°C, +80°C
- ▶ Vacuum : 0.13 bar (absolute pressure)
- ▶ Extruded Aluminium Alloy : 6063/T6 (according to EN 755.2, EN 573.3)
- ▶ Internal and external corrosion free coating



www.atlascopco.com/vacuum

DZS Mono-Claw & DZM Multi-Claw Vacuum & Low Pressure Solutions

A complete multi-claw vacuum pumping system in a box. A solution perfectly designed to meet your larger process demands with a central vacuum system based on the renowned Atlas Copco compressor philosophy.



DZS 300 V Claw
Multi-Claw Vacuum System

completely controllable system ranging from 44 to 1,230 m³/h integrated into one cabinet with a simple 'plug & play' concept.

Oil-Sealed Rotary Vane Vacuum Pumps

The GVS 16-630 A series operates according to the proven oil-sealed rotary vane principle that has been successfully used for many years in all general industrial vacuum applications. The GVS 16-630 A series is a robust and highly regarded product coming from a technologically advanced market leading design.



GVC500-P2-100B

Oil-Sealed Rotary Screw Vacuum Pumps

Innovative, Intelligent Vacuum Pumps

The GHS VSD+ Series vacuum pumps are ideal for a wide range of applications in canning, glass bottle and container production, packaging, pipeline drying, pick and place and many more. These vacuum pumps consume approximately 50% less energy than alternative technologies. They are among the most

market in the capacity range where some other technologies.



GHS 350-5400
VSD+



www.pneumatech.com

Desiccant Dryers



Pneumatech PH series PB Series - blower purge desiccant dryers PB Series - zero purge desiccant dryers PE Series - heated purge desiccant dryers PH Series - welded heatless dryers

Gas Generators

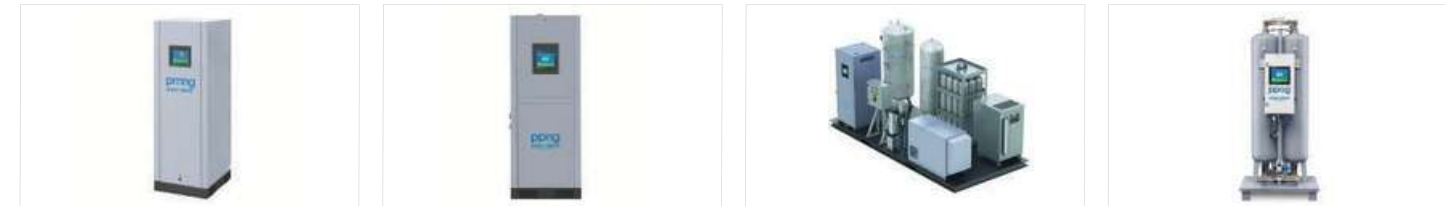

PMNG Series - membrane nitrogen generator PPNG Series - PSA nitrogen generators PPNG Skid PPOG Series - PSA oxygen gas generators



www.omi-italy.it



Energy saving air dryers Standard filter Adsorption dryers Oil water separator



High temperature dryers High Temperature filter High pressure air dryers Differential Pressure Gauge



After coolers ALPS filter Water chiller Air water cooler



COMPRESSORS AND AIR PIPELINES



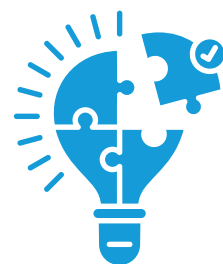
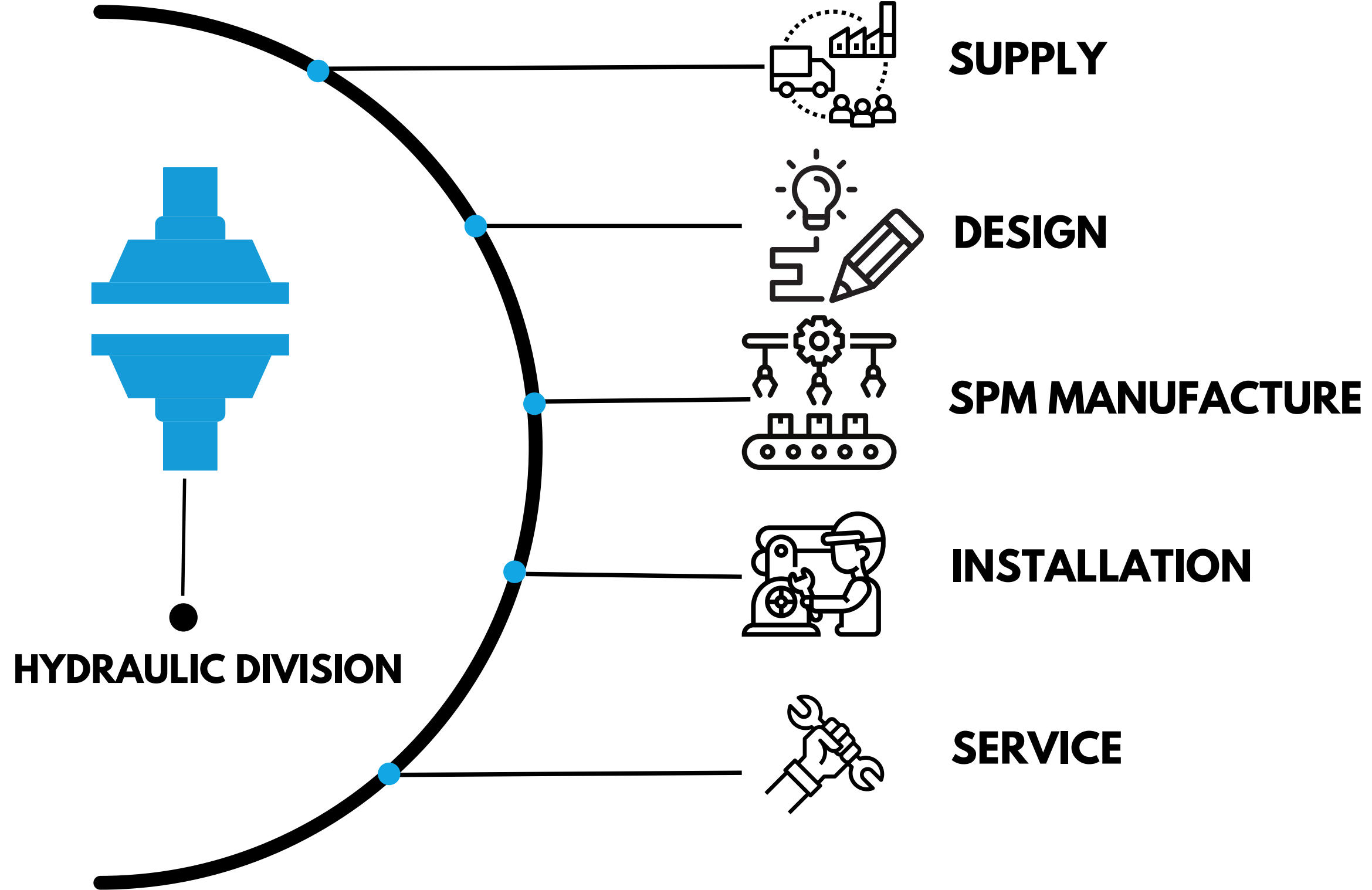



Mishel Hydraulics is leading manufacturer of Standard and Custom-built hydraulic cylinders.

Custom hydraulic cylinders play a key role of our business.

Mishel Hydraulics' s in-house application and design team ensures that the features and materials for each product will be best design as per application.

Cylinder Sizes

- Bore Sizes-40mm to 350mm
- Maximum Stroke Length-Up to 3000mm
- Operating Pressure- Up to 350 Bar



Integrated Valve options

- Counterbalance <
- Solenoid Control <
- Pilot operated check valve <
- LVDT <
- Proximity Sensor <



Hydraulic Cushions

- Front and Rear Cushions
- Fixed and adjustable
- Progressive deceleration profile



Mounting Options

- Flange <
- Clevis <
- Trunnion <
- Foot Mount <



Our Scope Of Product

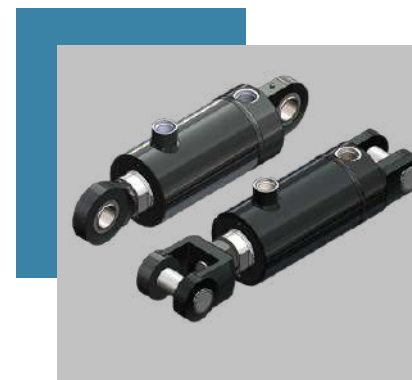

Hydraulic Cylinders



Hydraulic Motors



Hydraulic Power Packs

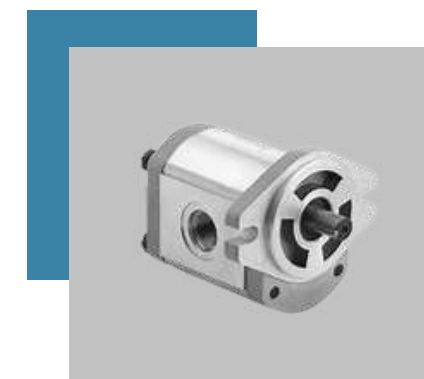

Hydraulic Pumps



Hydraulic Valves



HYDRAULIC PROJECT





MECHATRONICS GROUPS

HEAD QUARTERS

MECHATRONICS INDUSTRIAL EQUIPMENT FZ - L.L.C.

Plot No. 685-5715 at Dubai Production City, Dubai, UAE
TEL: +971 4 267 4311, FAX: +971 4 267 4312
Mob: +971 50 5681055
Email: mechtron@mechatronics.ae
www.mechatronics.ae

DANIKA AUTOMATION TECHNOLOGY L.L.C.

Tel: +971 2 5551255, Fax: +971 2 5551955
Mob: +971 56 689 7910
P.O.Box: 91183, Abu Dhabi, U.A.E.
E-mail: danika@mechatronics.ae
www.mechatronics.ae

MECHATRONICS INDUSTRIAL EQUIPMENTS L.L.C. - RAK

Tel: +971 7 2280717, Fax: +971 7 2280717
Mob: +971 50 1817324
P.O.Box: 19104, RAK, U.A.E.
E-mail: mechtron@mechatronics.ae
www.mechatronics.ae

MECHATRONICS INDUSTRIAL EQUIPMENT -AL QUSAIS

P.O.Box: 19104, Al Qusais Industrial Area - Dubai
Tel: +971 42989272
Mob: +971 54 547 0182
E-mail: bestim@mechatroncis.ae
www.mechatroncis.ae

MECHATRONICS INDUSTRIAL EQUIPMENT -QATAR

Tel: +974 44581155, Fax: +974 44689135
Mob: +974 50 299979
P.O.Box: 39233, Logistics Park GWC - Al Wukair, Doha, Qatar
E-mail: contact@mechatronicsqatar.com
www.mechatronicsqatar.com

MECHATRONICS INDUSTRIAL EQUIPMENTS-BAHRAIN

Tel: +973 17280059, Fax: +973 17910045
Mob: +973 38 021222
P.O. Box: 70454 Sitra, Kingdom of Bahrain
Email: contact@mechatronicsbh.com
www.mechatronicsbh.com

FLOWLINES TECHNOLOGY LLC

Tel: +971 4 267 6286
Mob: +971 54 582 2678
P O Box: 19104, Dubai - United Arab Emirates
Email: info@flowlinestechonology.com
www.flowlinestechonology.com

MECHATRONICS CONTROL EQUIPMENTS (INDIA) PVT. LTD

MOB: +91-44-28558484 / +91-95660 06666
Gulam, Wallahjah Rd, Murthasa, street,
Chennai, Tamil Nadu 600002
Sales1@mechatronicscontrol.com / md@mechatronicscontrol.com
www.mechatronicscontrol.com

OUR FACTORY : MISHEL HYDRAULICS

Telephone: +91 4427176161
Contact : +91 90434 66335
No.S14, Sipcot Industrial park, Sriperumbudur,
Kanchipuram district, Tamilnadu - 602105.
Mail Id : info@mishelhydraulics.com



ISO CERTIFICATE

CERTIFICATE EMS

نظام إدارة البيئة

EMS CERTIFICATE

Certificate of Registration



This is to certify that the Environment Management System of

MECHATRONICS INDUSTRIAL EQUIPMENT L.L.C.

P.O.Box:19104,
Al Qusais Industrial Area 1, Dubai, United Arab Emirates.

Has been independently assessed and is compliant with the requirements of

ISO 14001:2015

(Environmental Management System)

This Certificate is applicable to the following product or services ranges:

Water Cooling & Heating Equipment Trading, Water Desalination Equipment Trading, Inspection & Testing Equipment Trading, Measuring & Control System Installation, Solar Energy Systems & Components Trading, District Cooling Services, Industrial Plant Equipment & Spare Parts Trading, Electromechanical Equipment Installation and Maintenance, Pumps, Engines, Valves & Spare Parts Trading, Water Treatment & Purification Equipment Trading.

CERTIFICATE NO: AE 1000096/02/E

Date of this Certificate 30 OCT 2023 Date of Initial Registration 30 OCT 2023
Date of Certificate Expiry 29 OCT 2026 Re-certification Due 29 OCT 2026

Director



Issue No.01



This certificate is property of LEMS and remains valid subject to satisfactory surveillance audits. Certified organization is responsible for maintaining the compliance of relevant standard rules. Any significant changes in the scope of the certification or standard referred above renders this certificate invalid.

LEMS QUALITY & STANDARDIZATION CERTIFICATES ISSUING SERVICES

www.lmscert.com

Accreditation Service For Certifying Bodies LLC (ASCB)
8 The Green, Dover, DE, 19901, United States.

Accreditation service for certification bodies, LLC (ASCB) has assessed LEMS as a certifying body for compliance with ISO 17021:2015 conformity assessment. This certificate can be verified on www.lmscert.com

CERTIFICATE QMS

نظام إدارة الجودة

QMS CERTIFICATE

Certificate of Registration



This is to certify that the Quality Management System of

MECHATRONICS INDUSTRIAL EQUIPMENT L.L.C.

P.O.Box:19104,
Al Qusais Industrial Area 1, Dubai, United Arab Emirates.

Has been independently assessed and is compliant with the requirements of

ISO 9001:2015

(Quality Management System)

This Certificate is applicable to the following product or services ranges:

Water Cooling & Heating Equipment Trading, Water Desalination Equipment Trading, Inspection & Testing Equipment Trading, Measuring & Control System Installation, Solar Energy Systems & Components Trading, District Cooling Services, Industrial Plant Equipment & Spare Parts Trading, Electromechanical Equipment Installation and Maintenance, Pumps, Engines, Valves & Spare Parts Trading, Water Treatment & Purification Equipment Trading.

CERTIFICATE NO: AE 1000096/01/Q

Date of this Certificate 30 OCT 2023 Date of Initial Registration 30 OCT 2023
Date of Certificate Expiry 29 OCT 2026 Re-certification Due 29 OCT 2026

Director



Issue No.01



This certificate is property of LEMS and remains valid subject to satisfactory surveillance audits. Certified organization is responsible for maintaining the compliance of relevant standard rules. Any significant changes in the scope of the certification or standard referred above renders this certificate invalid.

LEMS QUALITY & STANDARDIZATION CERTIFICATES ISSUING SERVICES

www.lmscert.com

Accreditation Service For Certifying Bodies LLC (ASCB)
8 The Green, Dover, DE, 19901, United States.

Accreditation service for certification bodies, LLC (ASCB) has assessed LEMS as a certifying body for compliance with ISO 17021:2015 conformity assessment. This certificate can be verified on www.lmscert.com

CERTIFICATE OHSMS

نظام إدارة الصحة والسلامة

OHSMS CERTIFICATE

Certificate of Registration



This is to certify that the Occupational Health & Safety Management System of

MECHATRONICS INDUSTRIAL EQUIPMENT L.L.C.

P.O.Box:19104,
Al Qusais Industrial Area 1, Dubai, United Arab Emirates.

Has been independently assessed and is compliant with the requirements of

ISO 45001:2018

(Occupational Health & Safety Management System)

This Certificate is applicable to the following product or services ranges:

Water Cooling & Heating Equipment Trading, Water Desalination Equipment Trading, Inspection & Testing Equipment Trading, Measuring & Control System Installation, Solar Energy Systems & Components Trading, District Cooling Services, Industrial Plant Equipment & Spare Parts Trading, Electromechanical Equipment Installation and Maintenance, Pumps, Engines, Valves & Spare Parts Trading, Water Treatment & Purification Equipment Trading.

CERTIFICATE NO: AE 1000096/03/H

Date of this Certificate 30 OCT 2023 Date of Initial Registration 30 OCT 2023
Date of Certificate Expiry 29 OCT 2026 Re-certification Due 29 OCT 2026

Director



Issue No.01



This certificate is property of LEMS and remains valid subject to satisfactory surveillance audits. Certified organization is responsible for maintaining the compliance of relevant standard rules. Any significant changes in the scope of the certification or standard referred above renders this certificate invalid.

LEMS QUALITY & STANDARDIZATION CERTIFICATES ISSUING SERVICES

www.lmscert.com

Accreditation Service For Certifying Bodies LLC (ASCB)
8 The Green, Dover, DE, 19901, United States.

Accreditation service for certification bodies, LLC (ASCB) has assessed LEMS as a certifying body for compliance with ISO 17021:2015 conformity assessment. This certificate can be verified on www.lmscert.com



**WE THANK YOU FOR YOUR VALUABLE TIME
AND ATTENTION**

CONTACT US



mechtron@mechatronics.ae



+971 4 267 4311



www.mechatronics.ae

